

A438A - A438A

ATTACCHI SPECIFICI PER - SPECIFIC FITTING KIT FOR
KIT DE MONTAGE SPECIFIQUE POUR - SPEZIFISCHER MONTAGEKIT F R
ANLAJE ESPECCEFICO PARA

KYMCO PEOPLE S 250cc 2006

ISTRUZIONI DI MONTAGGIO - MOUNTING INSTRUCTIONS
INSTRUCTIONS DE MONTAGE - BAUANLEITUNG - INSTRUCCIONES DE MONTAJE

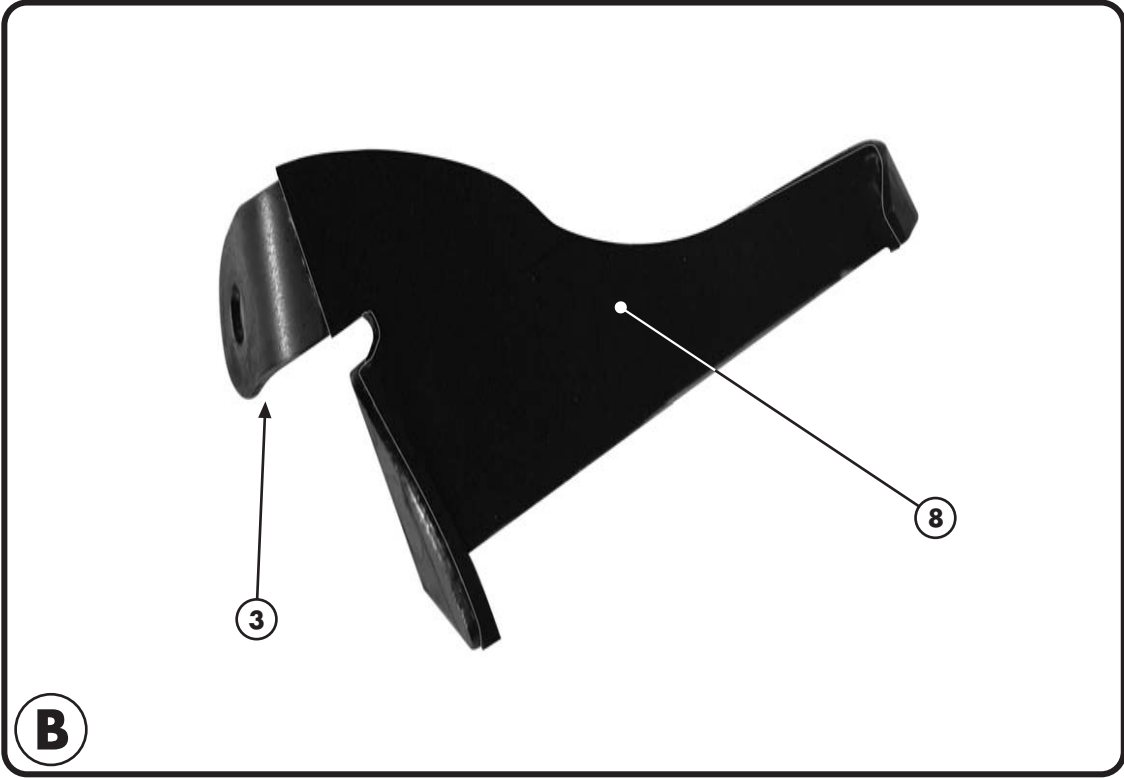
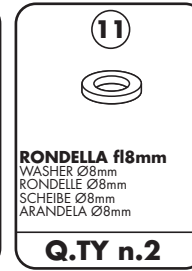
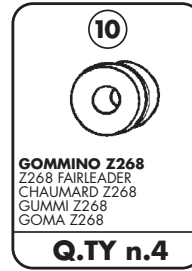
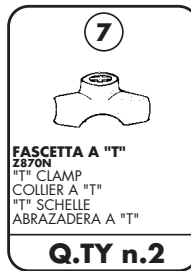
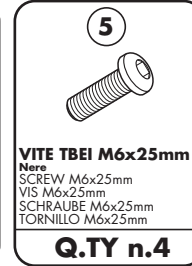
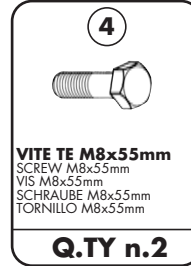

A438A - A438A

ATTACCHI SPECIFICI PER - SPECIFIC FITTING KIT FOR
 KIT DE MONTAGE SPECIFIQUE POUR - SPEZIFISCHER MONTAGEKIT F R
 ANCLAJE ESPECCEFICO PARA

KYMCO PEOPLE S 250cc 2006

ISTRUZIONI DI MONTAGGIO - MOUNTING INSTRUCTIONS
 INSTRUCTIONS DE MONTAGE - BAUANLEITUNG - INSTRUCCIONES DE MONTAJE

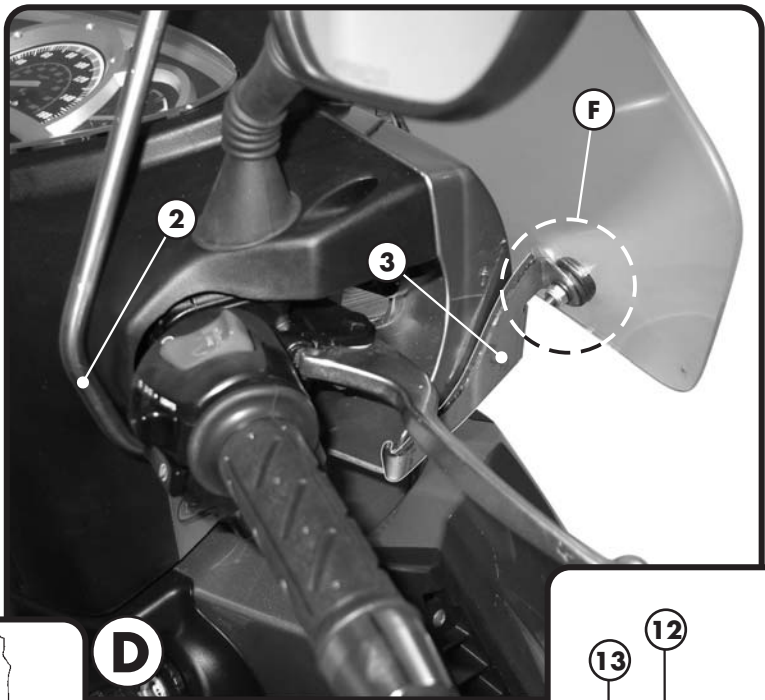
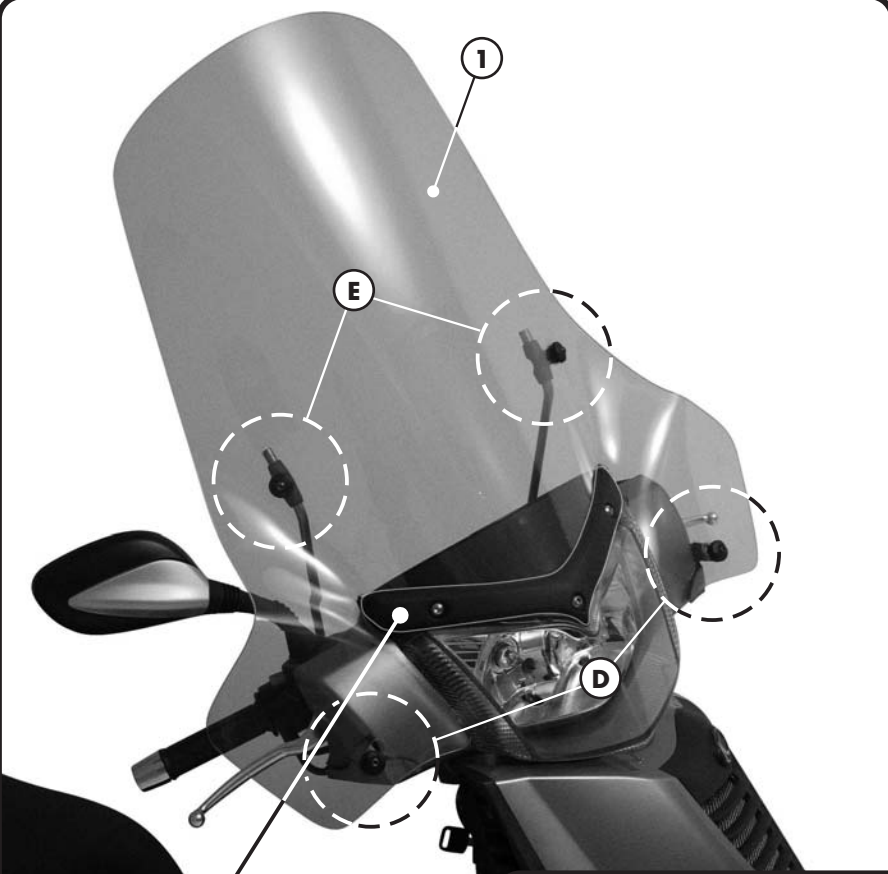

12

RONDELLA f16mm
 WASHER Ø6mm
 RONDELLE Ø6mm
 SCHEIBE Ø6mm
 ARANDELA Ø6mm

Q.TY n.2

13

DADO A.B. RIB. M6
 BOLT M6
 ECROU M6
 MUTTER M6
 TUERCA M6

Q.TY n.2

C

MONTARE LA MODANATURA ORIGINALE
 UTILIZZANDO TUTTI I PARTICOLARI ORIGINALI

MOUNT THE ORIGINAL WINDSCREEN
 FAIRING USING THE ORIGINAL FIXINGS

MONTER LE LISTON D'ORIGINE EN
 UTILISANT TOUTES LES PIECES
 D'ORIGINE

MONTIEREN SIE DIE ORIGINAL
 VERZIERUNG MIT DEN ORIGINAL
 TEILEN, DIE SIE VORHER ABMONTIERT
 HATTEN

MONTAR EL CARENADO ORIGINAL
 UTILIZANDO TODOS LOS
 PARTICULARES ORIGINALES

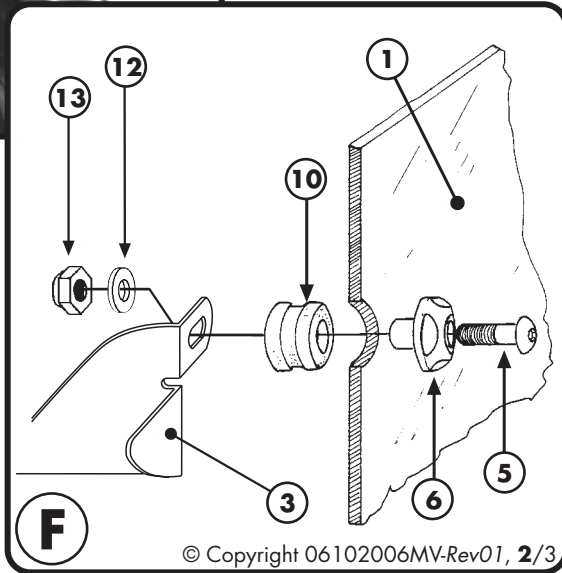
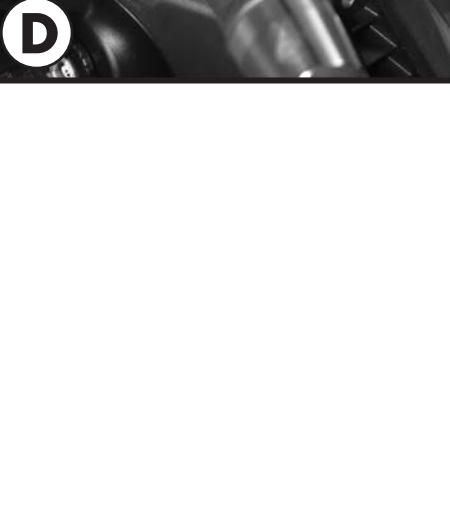
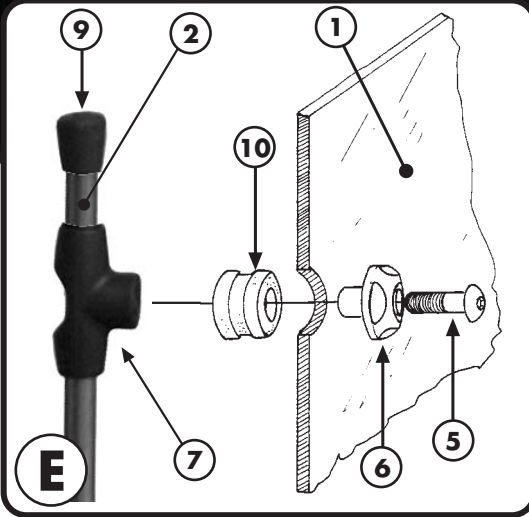

**ATTACCHI SPECIFICI PER - SPECIFIC FITTING KIT FOR
KIT DE MONTAGE SPECIFIQUE POUR - SPEZIFISCHER MONTAGEKIT F R
ANCLAJE ESPECCEFICO PARA**

KYMCO PEOPLE S 250cc 2006

ISTRUZIONI DI MONTAGGIO - MOUNTING INSTRUCTIONS
INSTRUCTIONS DE MONTAGE - BAUANLEITUNG - INSTRUCCIONES DE MONTAJE

I ISTRUZIONI DI MONTAGGIO

1. MONTARE IL SUPPORTO N°2 COME INDICATO IN FOTOGRAFIA A;
2. FISSARE LA MOUSSE PROTETTIVA N°14 COME INDICATO IN FOTOGRAFIA B SIA SUL SUPPORTO N°3 DESTRO CHE SINISTRO;
3. PROCEDERE NEL MONTAGGIO DEL PARABREZZA N°1 (NON INCLUSO) COME MOSTRATO IN FOTOGRAFIA C, FACENDO RIFERIMENTO ALLE IMMAGINI E E D;
4. FARE PARTICOLARE ATTENZIONE AL POSIZIONAMENTO DEL SUPPORTO N°3: DEVE ADERIRE ALLA CARENATURA DEL MANUBRIO COME MOSTRATO IN FOTOGRAFIA D;
5. ULTIMARE IL MONTAGGIO CONTROLLANDO CHE TUTTE LE VITI SIANO SERRATE BENE.

GB MOUNTING INSTRUCTIONS

1. MOUNT THE SUPPORT N° 2 AS SHOWN IN PICTURE A;
2. FIX THE PROTECTIVE RUBBER PAD AS SHOWN IN PICTURE B BOTH ON THE SUPPORT N° 3 LEFT AND RIGHT SIDE;
3. PROCEED WITH THE MOUNTING OF THE WINDSCREEN N° 1 (NOT INCLUDED) AS SHOWN IN PICTURE C MAKING REFERENCE TO THE PICTURES E AND D;
4. PAY PARTICULAR ATTENTION TO THE POSITIONING OF THE SUPPORT N° 3: THIS SHOULD ADHERE TO THE HANDLEBAR FAIRING AS SHOWN IN PICTURE D;
5. LASTLY CHECK THAT ALL SCREWS HAVE BEEN TIGHTENED.

F INSTRUCTIONS DE MONTAGE

1. MONTER LES SUPPORTS N°2 COMME INDIQUE EN PHOTO A ;
2. FIXER LES MOÛSES DE PROTECTION N°14 SUR LES PATTES N°3, DROITE ET GAUCHE, COMME ILLUSTRE EN PHOTO B ;
3. PROCEDER AU MONTAGE DU PARE-BRISE (NON INCLUS) COMME MONTRE EN PHOTO C ET EN SE REFERANT AUX CROQUIS E ET F ;
4. FAIRE PARTICULIEREMENT ATTENTION AU POSITIONNEMENT DES PATTES N°3 : ELLES DOIVENT COLLER LE CARENAGE DU GUIDON ;
5. TERMINER LE MONTAGE EN CONTROLANT LE BON SERRAGE DE TOUTES LES VIS.

D BAUANLEITUNG

1. MONTIEREN SIE DIE HALTERUNG NR. 2 WIE IM BILD A BESCHRIEBEN;
2. BEFESTIGEN SIE DAS MOOSGUMMI NR. 14 WIE IM BILD B BESCHRIEBEN AUF DIE HALTERUNG NR. 3 RECHTE UND LINKE SEITE;
3. MONTIEREN SIE DAS WINDSCHILD NR. 1 (NICHT VORHANDEN) WIE IM BILD C BESCHRIEBEN, NEHMEN SIE AUF DIE BILDER E UND D BEZUG;
4. PASSEN SIE AUF DIE POSITION DER HALTERUNG NR. 3 AUF, DIESE SOLL AN DER LENKERVERKLEIDUNG PERFEKT HAFTEN, WIE IM BILD D BESCHRIEBEN;
5. ZULETZT ÜBERPRÜFEN SIE, DASS ALLE SCHRAUBEN FESTGEZOGEN WURDEN.

ES

INSTRUCCIONES DE MONTAJE

1. MONTAR EL SOPORTE N°2 TAL Y COMO SE INDICA EN LA FOTO A;
2. FIJAR LA ESPUMA ADHESIVA PROTECTORA N°14, TAL Y COMO SE INDICA EN LA FOTO B, SOBRE EL SOPORTE N°3 DEL LADO DERECHO E IZQUIERDO;
3. EJECUTAR EL MONTAJE DE LA PANTALLA N°1 (NO INCLUIDO) TAL Y COMO SE INDICA EN LA FOTO C, CON REFERENCIA A LAS FOTOS E Y D;
4. PRESTAR ESPECIAL ATENCION EN LA POSICION DEL SOPORTE N°3, SE DEBE JUNTAR A LA CANALETA, TAL Y COMO SE MUESTRA EN LA FOTO D;
5. FINALIZAR EL MONTAJE COMPROBANDO QUE TODOS LOS TORNILLOS ESTÉN BIEN CERRADOS.